

Velodyne LiDAR[®] Puck 32MR[™]

HIGH RESOLUTION REAL-TIME LIDAR FOR
AUTONOMOUS SYSTEMS



Puck 32MR



The Puck 32MR utilizes Velodyne's patented technology to generate a data-rich image for precise real-time localization and object detection in autonomous mobile robots, shuttles and other autonomous systems. With robust surround-view perception in all light conditions, this sensor is optimized for outstanding indoor/outdoor performance. It produces a point cloud with minimal noise and the ability to detect low reflectivity objects at a range of 120 meters. By combining high-resolution 3D perception with a broad vertical field of view, the Puck 32MR accurately detects crosswalks, curbs and obstacles in warehouse aisles for safe and efficient navigation in roadway, commercial and industrial settings.

The Puck 32MR is designed for power-efficiency to extend vehicle operating time within broad temperature and environmental ranges without the need for active cooling. The sensor uses proven 905 nm Class 1 eye-safe technology and is assembled in Velodyne's state-of-the-art manufacturing facility. The use of readily available, off-the-shelf components enables scalability and attractive pricing for volume customers. Like other Velodyne sensors, the Puck 32MR has world-class technical support available across North America, Europe & Asia from the world's leading lidar company.



Puck 32MR at a glance

- Patented 360-degree rotational design
- 120 m range with compact form factor
- Best horizontal (360°) and vertical (40°) FoV
- Top vertical resolution in its class (0.33°)
- Best-in-class accuracy and calibrated intensity
- Superior power-efficiency & temperature range
- Firing exclusion & interference mitigation features
- Advanced features for minimizing false positives

DIMENSIONS *(Subject to change)*

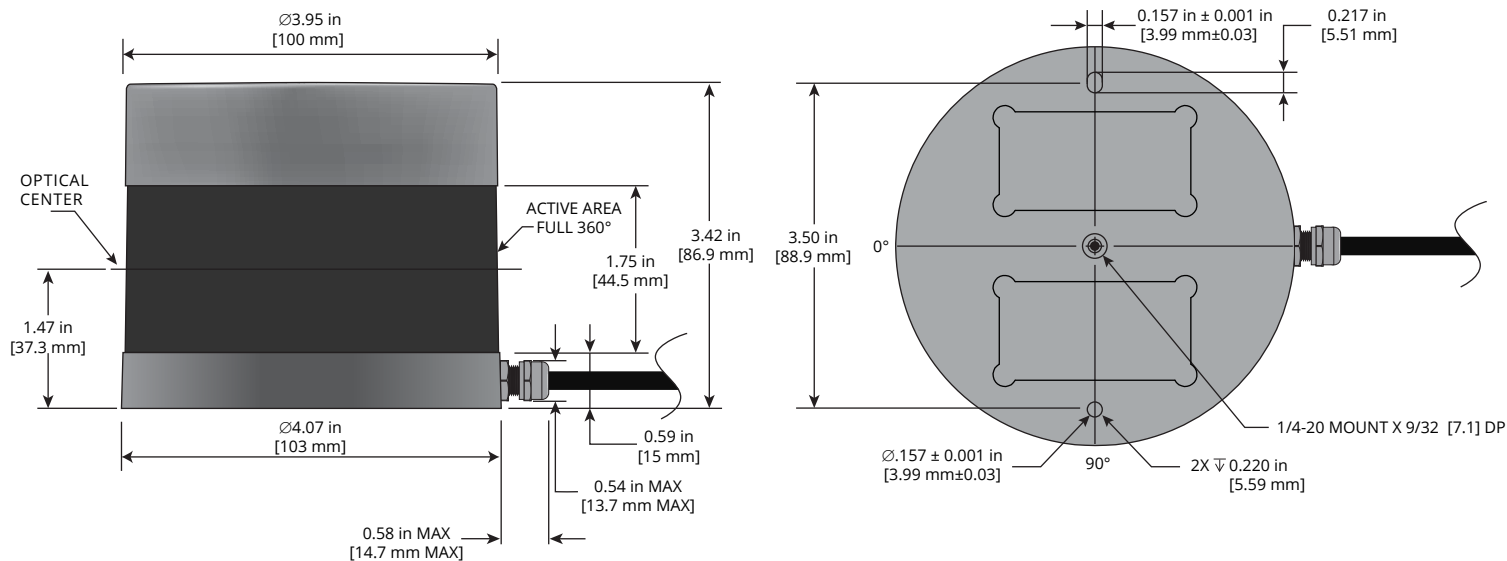

Real-Time Lidar Sensor

The Puck 32MR™ provides high definition 3-dimensional information about the surrounding environment.



Puck 32MR™

Specifications ¹

(Subject to change)

Sensor	<ul style="list-style-type: none"> • Channels: 32 • Measurement Range: 120 m @ 10% reflectivity • Range Accuracy: Up to ±3 cm (Typical)² • Horizontal Field of View: 360° • Vertical Field of View: 40° (-25° to +15°) • Minimum Angular Resolution (Vertical): 0.33° (non-linear distribution) • Angular Resolution (Horizontal/Azimuth): 0.1° to 0.4° • Frame Rate: 5 Hz to 20 Hz • Integrated Web Server for Easy Monitoring and Configuration
Laser	<ul style="list-style-type: none"> • Laser Product Classification: Class 1 – Eye-safe per IEC60825-1:2014 • Wavelength: ~903 nm
Mechanical/ Electrical/ Operational	<ul style="list-style-type: none"> • Power Consumption: 10 W (Typical)³ • Operating Voltage: 10.5 V – 18 V (with interface box and regulated power supply) • Weight: ~925 g (typical, without cabling and interface box) • Dimensions: See diagram on previous page • Environmental Protection: IP67 • Operating Temperature: -20°C to +60°C⁴ • Storage Temperature: -40°C to +85°C
Output	<ul style="list-style-type: none"> • 3D Lidar Data Points Generated: <ul style="list-style-type: none"> - Single Return Mode: ~600,000 points per second - Dual Return Mode: ~1,200,000 points per second • 100 Mbps Ethernet Connection • UDP Packets Contain: <ul style="list-style-type: none"> - Time of Flight Distance Measurement - Calibrated Reflectivity Measurement - Rotation Angles - Synchronized Time Stamps (µs resolution) • GPS: \$GPRMC and \$GPGGA NMEA Sentences from GPS Receiver (GPS not included)

63-9665 Rev-A

For more details and ordering information, contact Velodyne Sales (sales@velodyne.com)

1. These are projected specifications for final production parts. The specifications for any sample, prototype, or other non-final or pre-production parts may be different from the specifications in this document. For more information, please contact Velodyne Sales.
2. Typical accuracy refers to ambient wall test performance across most channels and may vary based on factors including but not limited to range, temperature and target reflectivity.
3. Operating power may be affected by factors including but not limited to range, reflectivity and environmental conditions.
4. Operating temperature may be affected by factors including but not limited to air flow and sun load.



CLASS 1 LASER PRODUCT

Copyright ©2019 Velodyne Lidar, Inc. Specifications are subject to change. Other trademarks or registered trademarks are property of their respective owners.